

# QUADRUS<sup>®</sup> EZ



## Dynamic Smart Camera

The Quadrus EZ smart camera provides an easy, integrated decoding solution for linear, stacked, and 2D symbols.

Specializing in reading low contrast applications, the Quadrus EZ decodes symbols directly marked by dot peen, laser etch, chemical etch, ink jet, and thermal transfer that are applied to materials such as metal, plastic, rubber, and glass.

### Quadrus EZ: At a Glance

- Decodes/second: up to 60
- Read Range: 2 to 10" (51 to 254 mm)
- Patented Quadrus Technology
- IP65 Enclosure



ESP<sup>®</sup>: Easy Setup Program software provides quick and easy setup and configuration of all Microscan readers.



EZ Trax<sup>™</sup>: Image capture and storage software provides tracking of symbol images.



EZ Button: This performs reader setup and configuration with no computer required.



Visible Indicators: Performance indicators include "good read" green flash and LEDs, as well as the label positioning tool.

For more information on this product, visit [www.quadrus-ez.com](http://www.quadrus-ez.com).

### Quadrus EZ: Available Codes

Linear

All Standard



2D Symbols



QR



Stacked

MicroPDF



PDF417



RSS



#### Ease of Use

Initial set up of the Quadrus EZ can be done in seconds. Position the symbol using the "X" pattern, then push the EZ button to read.

#### Field of View Locator & Good Read Flash

A blue "X" identifies the field of view center, allowing fast and accurate symbol placement. The Quadrus EZ emits a bright green flash (visible from all angles) signaling a successful read.

#### Extensive Focal Range

The Quadrus EZ offers four optical versions, factory adjustable from 2 to 10" (50.8 to 254 mm). Adding a camera can expand optical flexibility to increase focal ranges.

#### Ethernet Connectivity

Embedded Ethernet is an option available for high speed data and image transfer.

#### Dynamic Reading

High decode speeds and superior light collection allow the Quadrus EZ to meet the needs of applications with line speeds up to 600 feet per minute (180 meters/minute).

#### 2D Symbol Quality Reports

The Quadrus EZ provides printed reports on a variety of quality parameters which are useful in gauging readability of a symbol.

#### Video Input/Output

The Quadrus EZ features video input and output ports. This allows standard analog RS-170 cameras to be used, and a live video feed to view images.

#### Application Examples

- Printed circuits assembly
- Automotive
- Aerospace
- Semiconductor manufacturing

**MICROSCAN<sup>®</sup>**

# QUADRUS® EZ DYNAMIC SMART CAMERA

## SPECIFICATIONS AND OPTIONS

### MECHANICAL

**Height:** 2.25" (57 mm)  
**Width:** 2.5" (64 mm)  
**Depth:** 4.2" (107 mm)  
**Weight:** 12 oz. (340 g)

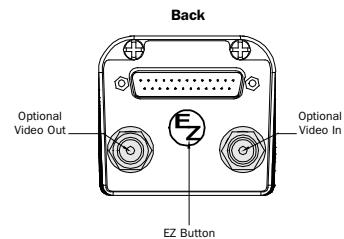
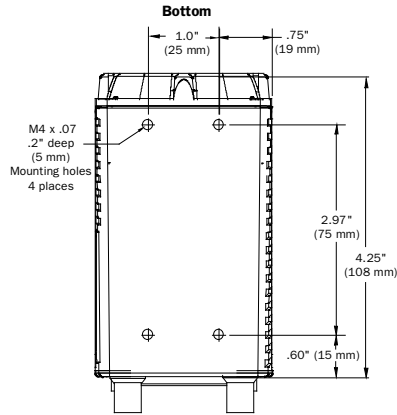
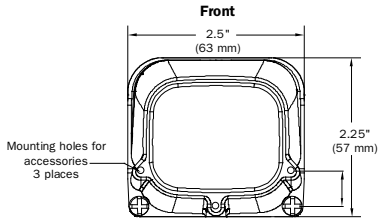

### ENVIRONMENTAL

**Enclosure:** IP65 (standard unit)  
**With Video I/O Option:** IP54  
**Operating Temperature:** 0° to 43°C (32° to 109°F), if mounted on a Microscan stand. If mounted on non-metal surface, maximum operating temperature is 40°C (104°F)  
**Storage Temperature:** -50° to 75° C (-58 to 167°F)  
**Humidity:** up to 90% (non-condensing)

### EMISSIONS/IMMUNITY

**ITE Disturbances:** EN55022: 1998 (radiated and conducted). Class A  
**General Immunity:** EN55024:1998 (residential)  
**Heavy Industrial Immunity:** EN61000-6-2:1999

### LIGHT SOURCE

**Type:** High output LEDs

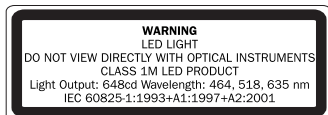

### LIGHT COLLECTION OPTIONS

Progressive scan, square pixel.  
 Software adjustable shutter speed, electronic mechanism  
**CCD Array:** 659 x 494 pixels  
**CMOS Array:** 640 by 480 pixels

### SYMBOLGY TYPES

**2D Symbologies:** Data Matrix (ECC 0-200), QR Code  
**Stacked Symbologies:** PDF417, Micro PDF417, RSS (Composite & Stacked)  
**Linear Bar Codes:** Code 39, Code 128, IBM BC412, I2 of 5, Pharmacoode, UPC/EAN

### FOUR OPTICAL VERSIONS

Medium Density CCD option shown (right)  
 For more information on Quadrus EZ's other optical versions including Narrow, Wide, and Extra Wide, please contact Microscan.

### MEASUREMENT

Shown in inches (mm)

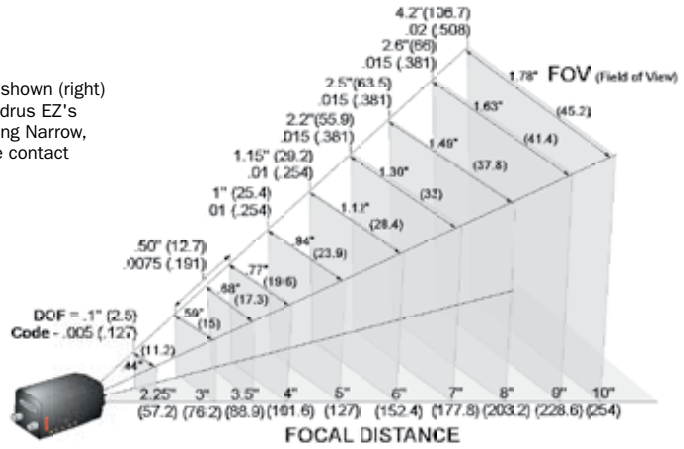

### STANDARD OFFERING

#### CONNECTORS/PIN ASSIGNMENTS

**Host Connector:** 25-pin D-subminiature plug

Pin No.	Host RS232	Host & Aux RS232	Host RS422/485	In/Out
1	Chassis ground <sup>a</sup>			
2	TxD			Out
3	RxD			In
4	RTS	TxD		Out
5	CTS	RxD		In
6	Output 1 (+)			Out
7	Signal Ground <sup>b</sup>			
8	Output 2 (+)			Out
9	Trigger (-)			In
10	Trigger (+)			In
11	Default configuration <sup>c</sup>			
12	Input 1 (+)			In
13			RxD (+)	In
14			TxD (-)	Out
15	Output 3 (+)			Out
16			RxD (-)	In
17	Power Ground <sup>d</sup>			
18	Power +10 to 28 VDC			In
19			TxD +	Out
20	Output 1 (-)			Out
21	Output 2 (-)			Out
22	Output 3 (-)			Out
23	Input 1 (-)			In
24	New master (-)			In
25	New master (+)			In

<sup>a</sup>Chassis ground: Used to connect chassis body to earth ground only. Not to be used as power or signal return.  
<sup>b</sup>Signal ground: Used for communication and signal line grounds only. Not to be used as power or chassis return.  
<sup>c</sup>The default is activated by connecting pin 11 to ground pin 7.  
<sup>d</sup>Power ground: Used for power return only. Caution: If using your own power supply, verify correct connection of power and ground lines. Incorrect connections or use of "Chassis ground," "Power ground," and "Signal ground" lines could cause equipment or software failure.

### ETHERNET OPTION

**Host Connector:** Pins Utilized

Pin No.	Function	In/Out
13	Ethernet RxD (+)	In
14	Ethernet RxD(-)	In
16	Ethernet TxD (-)	Out
19	Ethernet TxD (+)	Out

### VIDEO INPUT (Option)

**Signal System:** Progressive scan  
**Number of Scanning Lines:** 525 lines/non-interlaced  
**Input:** Analog 1 Vp-p

### VIDEO OUTPUT (Option)

**Signal System:** EIA  
**Number of Scanning Lines:** 525 lines/ 2:1 interlaced  
**Output:** Analog 1 Vp-p/75 ohm

### READ PARAMETERS

**Pitch:** ±30° **Skew:** ±30° **Tilt:** 360°  
**Decode Rate:** Up to 60 decodes per second  
**Focal Range:** 2 to 10 inches (factory adjustable)

### INDICATORS

**LEDs:** Read Performance, Power, Read Status, and Network Status  
**Beeper:** Good read, match/mismatch, noread, serial command confirmation, on/off

### COMMUNICATION PROTOCOLS

**Standard Interface:** RS-232, RS-422, RS-485, RS-232, Daisy Chain  
**Optional Interface:** Ethernet

### ELECTRICAL

**Power Requirements:** Input, 10 to 28 VDC, 200 mV p-p max ripple, 270 mA at 24 VDC (typ.- CMOS), 333 mA at 24 VDC (typ.-CCD).  
**Trigger, New Master, Input 1:** (Optoisolated) 5 to 28 VDC rated, (12mA at 24 VDC).  
**Outputs 1/2/3:** (Optoisolated) 1 to 28 VDC rated, (I<sub>CE</sub> < 100mA at 24 VDC, current limited by user).

### SAFETY CERTIFICATIONS

Designed for: FCC, CE, cUL, UL, BSMI



ISO 9001:2000  
**Certified QMS**

### ISO CERTIFICATION

Issued by RWTÜV, USA Inc.  
 ISO 9001:2000 – Cert No. 03-1212

©2006 Microscan Systems, Inc. Rev. B 10/06  
 Read Range and other performance data is determined using high quality Grade A symbols per ISO/IEC 15415 and ISO/IEC 15416 in a 25°C environment. For application-specific Read Range results, testing should be performed with symbols used in the actual application. Microscan Applications Engineering is available to assist with evaluations. Results may vary depending on symbol quality.  
**Warranty**—One year limited warranty on parts and labor. Extended warranty available.

# MICROSCAN®

### Microscan Systems, Inc.

Tel 425 226 5700/ 800 251 7711  
 Fax 425 226 8250

### Microscan Europe

Tel 31 172 423360/ Fax 31 172 423366

### Microscan Asia Pacific R.O.

Tel 65 6846 1214 / Fax 65 6846 4641

### www.microscan.com

**Tech Support:** helpdesk@microscan.com

**Product Information:** info@microscan.com